



Fill-Air™ Inflatable Packaging System

Efficient On-Site, On-Demand Production of Lightweight,
Air Cushion Packaging.



Sealed Air Corporation

Fill-Air™ Inflatable Packaging System

The Fill-Air™ System quickly converts compact rolls of specially formulated tubular material into continuous, perforated chains of air-filled cushions. Fill-Air™ cushions can be produced in a wide range of sizes which provide numerous benefits to your packaging operation including:

- **On-Demand Packaging** – delivers air-filled cushions when you need them. No need for storage bins or bulky containers.
- **Versatile** – inflated cushions are excellent for a wide variety of void fill and light duty cushioning applications.
- **Saves Valuable Warehouse Space** – one compact Fill-Air™ 10" wide roll yields up to 375 cu. ft. of dunnage – the equivalent of twenty-eight 14 cu. ft. bags of loose fill.
- **Easy To Use** – just tear off the desired number of cushions and pack into place.
- **Fast** – produces up to 5 cu. ft. of dunnage per minute.
- **Clean** – no loose fill mess or dusty paper for you or your customers to clean up.
- **Lightweight** – reduces shipping costs.

- **Outstanding Protection** – provides maximum protection using minimum material. Your products travel securely and well protected, surrounded by a cushion of air.
- **Enhanced Customer Satisfaction** – your customers receive their goods in perfect condition, in clean, professional looking packages.
- **Environmental Benefits** – inflated cushions can be reused numerous times. Deflated cushions occupy only 1% of their inflated volume and can be recycled at Sealed Air® facilities.

Fill-Air™ Inflatable Packaging Applications:



Void Fill



Cushioning



Three Simple Steps Produce Clean Protective Packages Your Customers Will Appreciate



Step 1 – Group your products in the carton to make room for the Fill-Air™ cushions.



Step 2 – Once the desired cushion size is selected, tear off as many inflated cushions as needed.



Step 3 – Pack the cushions around your products and seal the carton.



The versatile, highly productive Fill-Air™ system can be used on-line or to supply on-demand cushions for multiple packaging stations.

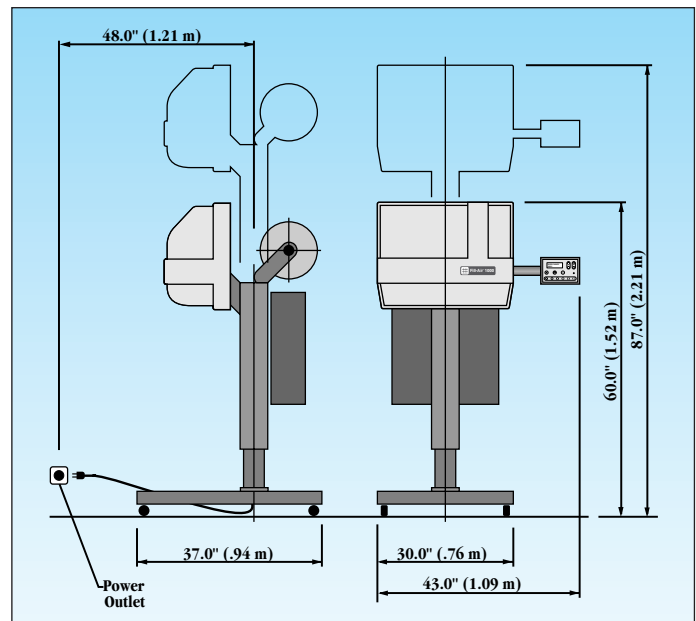

A Compact, Versatile System

- **Easy To Install** – free standing, mobile unit requires only a standard 110 volt, 15 amp outlet and minimum 80 psi air supply.
- **Easy To Use** – only minimum operator training is required.
- **Patented Sealing Technology** – ensures leak proof seals in every cushion.
- **Controlled Inflation Process** – maintains uniform pressure within each cushion for consistent product protection.
- **Uni-Locking Core** – works as an anti-lock brake mechanism to provide optimum web tension and material usage efficiency.
- **Uni-Locking Roll Guides** – lock the roll in place for precise web tracking and consistent inflation levels.
- **Advanced Multi-Function Keypad** – enables the operator to custom program frequently used bag sizes in nine languages.
- **Tool-Less Design** – allows the system to be serviced without the need for tools.

Fill-Air™ Material Roll Sizes

Product Number	Roll Width	Roll Length
FA-200	8"	1,800'
FA-250	10"	1,800'

Our Products Protect Your Products®



Jiffy Packer™ On-Line
Paper Packaging System



Rapid Fill®
Air-Filled Packaging System



Instasheeteer™
High-Speed Converting System



Accu-Cut™
Converting System



SpeedyPacker™
Foam-in-Bag Packaging System



Cell-Aire®
Polyethylene Foam



AirCap® and PolyCap®
Recycled Bubble Cushioning



Jiffy Mailer® Products

Sealed Air Corporation manufactures and markets a wide variety of materials and systems to protect products from damage caused by shock, vibration, abrasion, and electrostatic discharge.

For the 90's, we will continue our tradition of leadership by providing solutions – not compromises – through technological development and innovation.

Our Products Are Supported By:

- **Consultative sales representatives** who will work with you to determine the most cost-effective packaging method.
- **Package design and testing** at no charge to you.
- **Training** to ensure your personnel are using our products effectively and economically.
- **Local full line distributors** providing complete sourcing for all your packaging needs.
- **Multiple shipping points** throughout the U.S.
- **System installation and service** by local Sealed Air® Representatives and Authorized Equipment Distributors.
- **Worldwide availability** for those customers with international sourcing requirements.

Our Environmental Commitment

Sealed Air is committed to sound business practices based on the most current environmental information available. We have adopted a program that encompasses specific lines of action:

- **Source Reduction** – In our twenty seven packaging labs worldwide, we are continually striving to reduce the amount of packaging material needed to ensure adequate product protection.
- **Recycling** – Sealed Air recycles over 100 million pounds of paper and plastic each year.
- **Reusability** – Products are designed for maximum reuse.
- **Disposal** – Sealed Air® products are efficiently and safely incinerated, or take up minimal landfill space.

Distributed by:

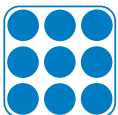

Sealed Air Corporation

Packaging Products Division

301 Mayhill Street, Saddle Brook, NJ 07663-5303
1-800-648-9093, Ext. 60 Fax: (201) 712-7070
www.sealedaircorp.com

Our Products Protect Your Products®

CORPORATE OFFICES: Park 80 East, Saddle Brook, NJ 07663

INTERNATIONAL: Australia, Brazil, Canada, China, England, Finland, France, Germany, Hong Kong, Italy, Japan, Korea, Malaysia, Mexico, Netherlands, New Zealand, Norway, Singapore, Spain, Sweden, Taiwan, Thailand.

INTERNATIONAL LICENSEES AND DISTRIBUTORS: Japan, South Africa.

 **50% TOTAL RECOVERED PAPER** © Reg. U.S. Pat. Off. © Sealed Air Corporation 1997. All Rights Reserved.
10% POST CONSUMER MATERIALS Printed in the U.S.A. on Recycled Paper.

D-110 6/97